

# THE AMERICAN MINERALOGIST

JOURNAL OF THE MINERALOGICAL SOCIETY OF AMERICA

Vol. 23

FEBRUARY, 1938

No. 2

## ATOMIC PACKING MODELS OF SOME COMMON SILICATE STRUCTURES

J. E. DORRIS, CLIFFORD FRONDEL, W. C. GÜSSOW, V. M. LOPEZ,  
C. S. LORD, WILLIAM PARRISH, AND J. A. SHIMER  
*Massachusetts Institute of Technology, Cambridge, Mass.*

### CONTENTS

Introduction . . . . .	65
Zircon . . . . .	66
Olivine . . . . .	67
Diopside . . . . .	70
Muscovite . . . . .	74
Sanidine . . . . .	76

### INTRODUCTION

*"In my opinion . . . the student, . . . will be well repaid if he makes models of the structure for himself . . . one gains an exceedingly intimate knowledge of the structure while building them . . . . No study of a diagram can teach as much . . . . Even when one has considerable experience of 'thinking in three dimensions' it is no easy matter to visualize a complex structure by studying a two-dimensional diagram."*<sup>1</sup>

The importance of models that illustrate the atomic packing in crystals has already been noted.<sup>2</sup> They serve a different purpose than the "nuclear" crystal models. Atomic packing models are helpful in the study of gliding, coordination, exsolution, isomorphism, polymorphism, cleavage, the relation between crystal structure and habit, and other problems in which a knowledge of the atomic positions, relative sizes and packing is essential. The nuclear models are largely restricted to show the symmetry and point positions and convey no idea of the relative atomic radii.

The silicates are among the most difficult structures to visualize. The purpose of this paper is to present construction data for models of some of the more representative silicates.

<sup>1</sup> Bragg, W. L., *Atomic Structure of Minerals*, Ithaca, 1937, p. 47.

<sup>2</sup> Buerger, M. J., and Butler, R. D., A technique for the construction of models illustrating the arrangement and packing of atoms in crystals: *Am. Mineral.*, vol. 21, pp. 150-172, 1936.

Buerger and Butler<sup>2</sup> have perfected a technique for the construction of atomic packing models. These are built on a scale of one inch = two Ångström units. The methods of calculation of the drilling coordinates are outlined in their paper and need not be described here. In the silicate models the silicon atoms are made of lead shot of such size that one nestles exactly in an oxygen tetrahedron. It was therefore unnecessary to calculate the silicon drilling coordinates or the silicon-oxygen bonds.

The models were prepared under the direction of Prof. M. J. Buerger, to whom we are indebted for many valuable suggestions. Mr. Ely Mencer prepared many of the photographs. The diagrams were made by the individual writers.

## ZIRCON

(J. A. Shimer)

The following data for the crystal structure of zircon are given by Wyckoff and Hendricks.<sup>3</sup>

Space Group  $D_{4h}^{19}$  Unit cell:  $a = 6.58\text{Å}$   
 $c = 5.93\text{Å}$

Zr is on Wyckoff's equipoint (b), (symmetry  $V_d$ ) at  $[[0, 0, 0]]$

Si is on Wyckoff's equipoint (a), (symmetry  $V_d$ ) at  $[[0, 0, \frac{1}{2}]]$

O is on Wyckoff's equipoint (h), (reflection planes) at  $[[0, u, v]]$ , where  $u = 0.20$ , or one-fifth the unit cell dimension  $a$ , and  $v = 0.34$ , or one-third  $c$ .

The Si atom, coordinates  $[[0, 0, \frac{1}{2}]]$ , has

Neighbors	Coordinates	Distance
4 O	$0, u, \frac{1}{2} - v$	1.62Å
2 Zr	$0, 0, \frac{1}{2}$	2.97Å
8 O	$\frac{1}{2}, u, v - \frac{1}{4}$	3.58Å

A Zr atom, coordinates  $[[0, 0, 0]]$ , has

Neighbors	Coordinates	Distance
4 O	$0, \frac{1}{2} - u, \frac{1}{4} - v$	2.05Å
4 O	$0, u, v$	2.41Å
2 Si	$0, 0, \frac{1}{2}$	2.97Å

We may consider the structure made up of strings parallel to the  $c$ -axis, each string being composed of alternate  $\text{SiO}_4$  and Zr units. Each Zr atom joins the  $\text{SiO}_4$  tetrahedra from the four neighboring strings. The O atoms in the silica tetrahedra were assumed to touch each other and the shortest distance between an O and a Zr atom was assumed to be the sum of their radii. Using these assumptions and the data given, the approximate atomic radii may be calculated as  $\text{O} = 1.32\text{Å}$ , and  $\text{Zr} = 0.73\text{Å}$ . Drilling coordinates and other data are given in Table 1.

In putting the model together, the  $\text{SiO}_4$  tetrahedra were first assembled. Then bridges of two tetrahedra and a connecting Zr atom were formed. These bridges were built up to form the model. Top and side views are shown in Figs. 1 and 2, respectively.

<sup>3</sup> *Zeits. Krist.*, vol. 66, pp. 73-102, 1927.

TABLE 1. DATA FOR THE CONSTRUCTION OF A PACKING MODEL OF ZIRCON

Ball designation	Ball diameter	Number of balls required for 2 unit cells	Drilling coordinates		Pin joins ball to
			$\rho$	$\phi$	
Zr	$\frac{11}{16}$ "	22	75	0, 180	O
			105	90, 270	O
O	$1\frac{5}{16}$ "	72	35	0, 120, 240	O
			160	180	Zr
			139.5	0	O

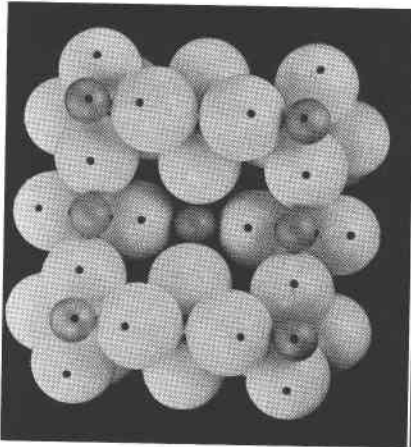

FIG. 1

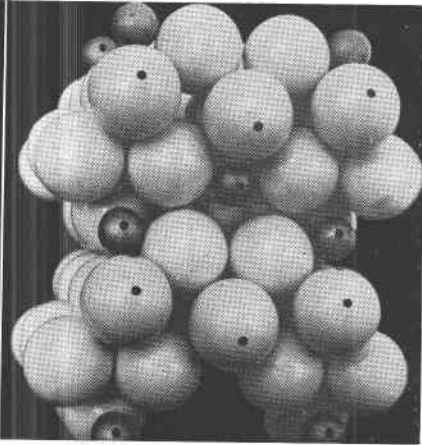

FIG. 2

FIG. 1. Top view of the zircon structure. Viewed parallel to  $c$  axis.

FIG. 2. Side view of the zircon structure. Viewed almost parallel to an  $a$  axis.

### OLIVINE

(J. E. Dorris)

The most complete structural description of the orthosilicate, olivine, is that of W. L. Bragg and G. B. Brown.<sup>4</sup> They determined the following data for  $Mg_2SiO_4$  (forsterite):

Space Group:  $V_h^{16}$

Unit Cell:  $a = 4.75\text{\AA}$

$b = 10.2\text{\AA}$

$c = 5.99\text{\AA}$

The calculation of the drilling coordinates (given in Table 2) is relatively simple once the structural plan is grasped. Diagrams illustrating the symmetry, coordination and packing are given in the paper cited, in

<sup>4</sup> *Zeits. Krist.*, vol. 63, pp. 538-556, 1926.

Strukturbericht,<sup>5</sup> and in a summary of silicate structures by W. L. Bragg.<sup>6</sup>

In general, the structure of olivine may be likened to one showing hexagonal close packing, in which the SiO<sub>4</sub> tetrahedra have been slightly displaced or thrust apart by the Mg atoms. The radius ratio of Mg to O is too great to permit close packing.

TABLE 2. DATA FOR THE CONSTRUCTION OF A PACKING MODEL OF OLIVINE

Ball designation*	Ball diameter	Number of balls required for the model as illustrated in Fig. 4	Drilling coordinates		Pin joins ball to
			$\rho$	$\phi$	
O (I)	$1\frac{5}{16}''$	18	35 145	0, 120, 240 0, 120, 240	2 O (III), O (II) 2 O (III), O (II)
O (II)	$1\frac{5}{16}''$	18	35 58.6 90 121.3 145	30 102, 318 0, 60 210 30	O (I) 2 Mg (I), 2 O (III) Mg (II) O (I)
O (III R) and O (III L)	$1\frac{5}{16}''$	36	35 58.6 90 145	30 102, 318 0, 60 30	O (I) Mg (I), Mg (II) O (II), O (III) O (I)
Mg (I)	$\frac{3}{4}''$	26	90	0, 79, 180 259	2 O (II), 2 O (III)
Mg (II)	$\frac{3}{4}''$	18	90 164	0, 79 210	2 O (III) O (II)

\* The same notation is used here as was used by Bragg and Brown in their original paper cited in footnote 6.

There are two types of magnesium atoms designated by the symbols Mg (I) and Mg (II). The Mg (I)-types occur at centers of symmetry between reflection planes. There are three different types of oxygen atoms, each having different drilling coordinates and denoted by the symbols O(I), O(II) and O(III). The O(I)-atoms are at the apices of pyramids formed by the silica tetrahedra and lie on reflection planes. The O(II)-and O(III)-atoms form the base of the pyramid and lie in the  $b-c$  axial plane. The O(III)-atoms lie between the reflection planes. Thus for a given silica tetrahedron, there are two O(II)-atoms for every O(I)- and O(III)-type.

<sup>5</sup> *Zeits. Krist.*, pp. 352-353, 1931.

<sup>6</sup> *Zeits. Krist.*, vol. 74, p. 242, 1930.

As indicated by its classification, olivine consists of independent  $\text{SiO}_4$  groups. Each group is linked to three Mg atoms which, in turn, link together the isolated  $\text{SiO}_4$  groups.

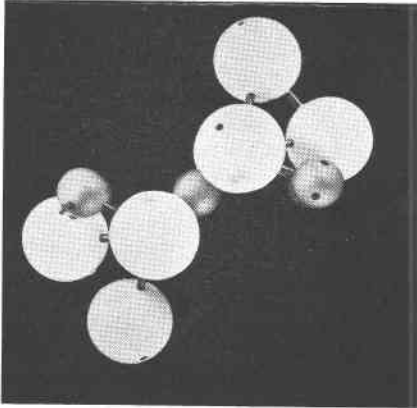

FIG. 3(a)

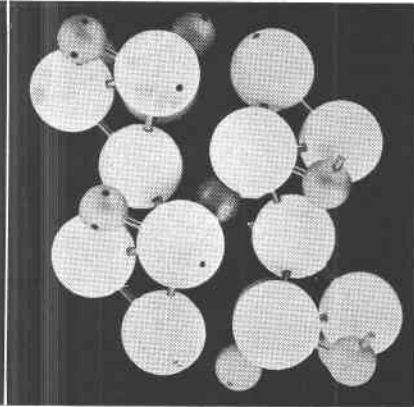

FIG. 3(b)

FIG. 3(a). Two  $\text{SiO}_4$  tetrahedra of olivine arranged about Mg (I) with the  $a$ -axis oriented in a N-S direction. The Si atoms are missing.

FIG. 3(b). Same as Fig. 3(a) but with two more tetrahedra added.

The assembling of the model will be made easier if the reader bears the following in mind. The fundamental unit of construction, or "building block" is the  $\text{SiO}_4$  tetrahedron with three Mg atoms attached. These units are built into a second unit which consists of six tetrahedra. The first step is the linking of the two tetrahedra by a Mg atom at a center

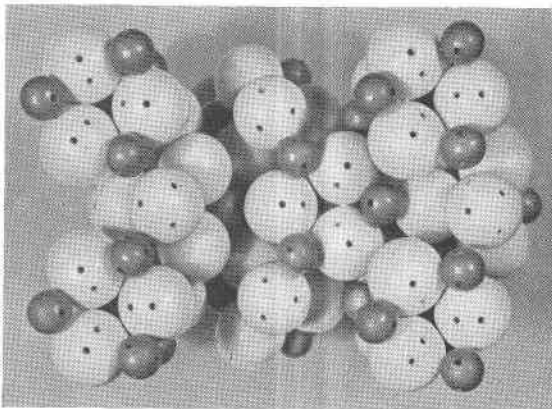

FIG. 4. The completed model of olivine viewed along  $a$ , with  $b$  oriented E-W and  $c$  is N-S.

of symmetry, Mg(II), as shown in Fig. 3(a). Two more tetrahedra are added as shown in Fig. 3(b). There are two vertical pairs of tetrahedra joined to one another by a single Mg atom at a center of symmetry. To complete the second unit, a third pair of tetrahedra is joined to either one of the first two pairs in a similar fashion. For a model of the size shown in Fig. 4, two more such units are constructed. It should be noted that the balls in the small SiO<sub>4</sub> unit and in the larger unit should be left open packed as shown in Figs. 3(a) and (b). The balls should not be put into close packing until the larger unit has been constructed. The separate units are then joined together by MgII atoms which lie on screw axes.

### DIOPSIDE

(William Parrish and W. C. Güssow)

Warren and Bragg<sup>7</sup> have determined the following data for the crystal structure of diopside:

Cell dimensions:	Space Group C <sub>2h</sub> <sup>6</sup> [C 2/c]
$a = 9.71\text{Å}$	Four molecules of CaMg(SiO <sub>3</sub> ) <sub>2</sub>
$b = 8.89\text{Å}$	per unit cell.
$c = 5.24\text{Å}$	
$\beta = 74^{\circ}10''$	
Coordination	Distance between atomic centers
Ca to 8 O	Ca—O, 2.35Å
Mg to 6 O	Mg—O, 2.10Å
Si to 4 O	O—O, 2.7–2.9Å

From these data we can calculate the approximate atomic radii as O = 1.35 Å, Ca = 0.95 Å, Mg = 0.70 Å. From the preliminary drawings it was apparent that unless a large number of trial drawings were made, the orientation of the tetrahedra in the silica chains would have to be changed in order to give the Ca and Mg atoms their correct sizes and coordination. We arbitrarily decided to use  $1\frac{1}{4}''$  for O and let the Mg and Ca take the sizes which would give them proper coordination. Thus the silica chain remains as calculated by Warren and Bragg but the relative atomic radii are slightly distorted. Better sizes would have been  $1\frac{3}{8}''$  for O,  $1''$  for Ca and  $\frac{3}{4}''$  for Mg. The drilling coordinates are given in Table 3.

The silica chains in the diopside structure are parallel to the *c*-axis. These chains are composed of regular SiO<sub>4</sub> tetrahedra. One oxygen atom of the tetrahedron is common to the adjoining tetrahedron so that the Si—O ratio reduces to the metasilicate ratio of 1 to 3. The chains are bound to each other by Ca and Mg atoms; the Ca coordinated to 8 and the Mg to 6 oxygen atoms.

<sup>7</sup> Warren, B., and Bragg, W. L., *Zeits. Krist.*, vol. 69, p. 168, 1928.

TABLE 3. DATA FOR THE CONSTRUCTION OF A PACKING MODEL OF DIOPSID

Ball designation	Ball diameter	Number of balls required for model as illustrated in Fig. 7	Drilling coordinates		Pin joins ball to
			$\rho$	$\phi$	
$O_{1R}$ (+ .84)	$1\frac{1}{4}''$	8	0 41 58.5 105.5 113.5 131	0 103.5 265.5 304 240.5 103.5	Ca
$O_{1L}$ (- .84)	$1\frac{1}{4}''$	4	0 49 66.5 74.5 121.5 139	0 103.5 240.5 304 265.5 103.5	Ca Mg  Ca
$O_{2R}$ (+2.14)	$1\frac{1}{4}''$	8	0 38 58.5 135.5	0 355 274.5 70.5	Mg
$O_{2L}$ (-2.14)	$1\frac{1}{4}''$	4	0 38 58.5 135.5	0 5 85.5 289.5	
$O_{3R}$ (+ .17)	$1\frac{1}{4}''$	8	0 38 74.5 98 113.5 133 157.5	0 185 124 0, 180 60.5 236 352	Ca
$O_{3L}$ (- .17)	$1\frac{1}{4}''$	8	0 38 74.5 98 113.5 157.5	0 175 236 0, 180 299.5 8	Ca
Mg	$\frac{7}{8}''$	8*	0 89	0 0	
$Ca_R$ (+1.52)	$1\frac{1}{4}''$	6*	0 41 76 123 133	0 103.5, 283.5 35, 215 133.5, 313.5 56, 236	O 1R O 2R O 3R O 3L
$Ca_L$ (-1.52)	$1\frac{1}{4}''$	6*	0 47 57 104 139	0 56, 236 133.5, 313.5 35, 215 103.5, 283.5	O 3R O 3L O 2L O 1L

\* If more Ca and Mg balls are added, as has been done with the model in Fig. 7, the symmetry is more readily seen.

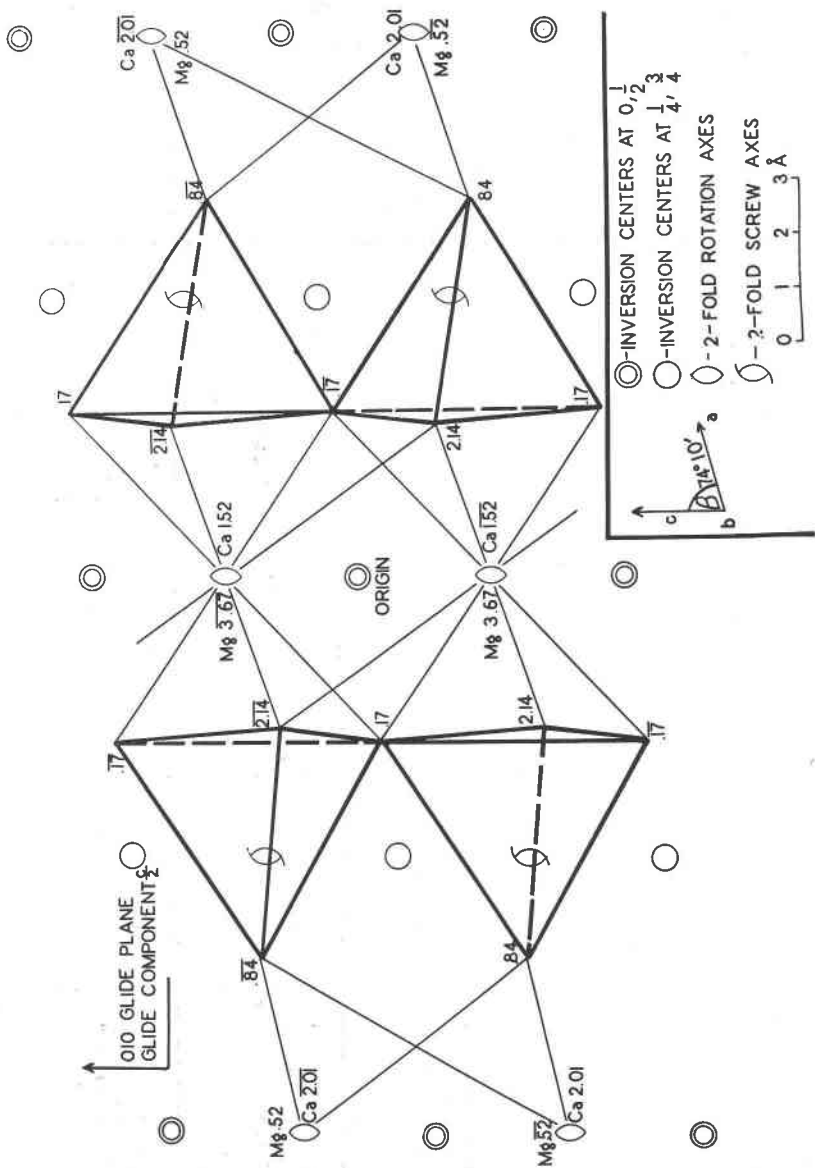

FIG. 5. Projection of the diopside structure on plane (010). This diagram shows the pinning directions and the symmetry elements. All the  $\phi$ -angles can be read directly. Numbers refer to the distance above or below the plane of the paper. To facilitate interpretation, Figs. 6(a) and (b) and Table 3 are figured in the same manner. Modified from Warren and Bragg.



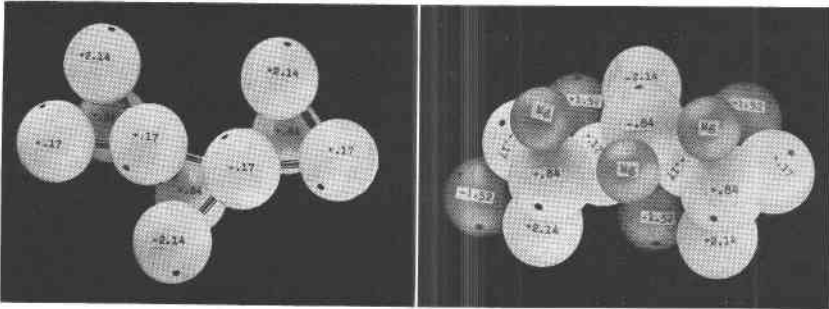

FIG. 6(a). The diopside metasilicate chain left open and the Si atoms omitted. Shows the pinning of the various O atoms.

FIG. 6(b). Bottom view of Fig. 6(a), with Si, Mg and Ca atoms added. This shows the packing of the important unit of the structure.

The construction of the model is made easier if the initial holes of the oxygen atoms are marked in such a manner that they can be easily recognized when putting the model together. It is advisable to make the silica chains first and leave them open as shown in Fig. 6(a). The whole silica chain is then closed and enough Ca and Mg atoms are added to tie two silica chains together. Figures 5-7 illustrate various aspects of the diopside structure.

The writers are indebted to Mr. O. N. Rove for aid in making the calculations.

### MUSCOVITE (Clifford Frondel)

Muscovite can be visualized as built up of paired "mica sheets" (extended planar  $\text{Si}_4\text{O}_{10}$  groups) placed so that the bases of the  $\text{SiO}_4$  tetrahedra are symmetrically opposed. A 12-coordinated K atom is situated between the opposing basal hexagonal oxygen rings of these sheets, with 8-coordinated OH groups situated at the center of the hexagons formed by the apical oxygens of the silica tetrahedra in each oppositely facing sheet.

These blocks of paired sheets, with their K and OH atoms, are stacked in the crystal so that each block is displaced over the next underlying block for a distance of  $\frac{1}{3} a$  at an angle of  $30^\circ$  with  $b$ , and are bound to the adjacent blocks by a layer of 6-coordinated Al atoms (Mg or Fe in phlogopite or biotite). Diagrams illustrating the stacking of the blocks and the positions of the various atoms can be found in the original description by Jackson and West<sup>8</sup> and in a recent account by Bragg.<sup>9</sup>

<sup>8</sup> Jackson, W. W., and West, J., *Zeits. Krist.*, vol. 76, p. 211, 1930; vol. 85, p. 160, 1933.

<sup>9</sup> Bragg, W. L., *Atomic Structure of Minerals*, Ithaca, pp. 205-210, 1937.

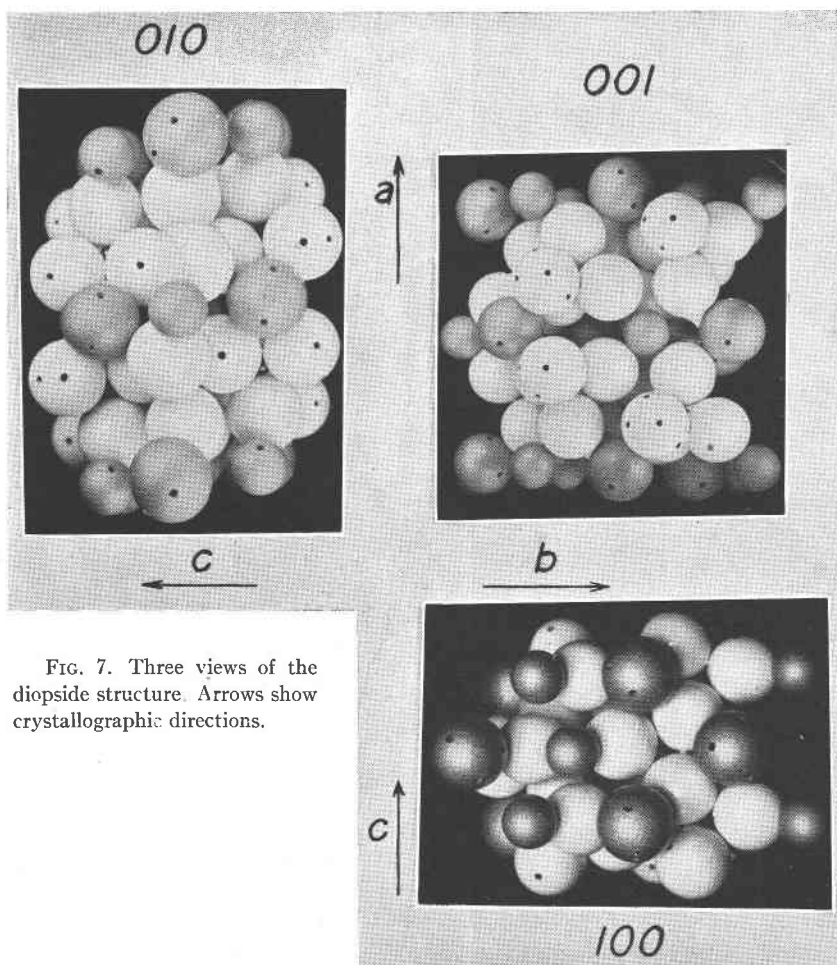

FIG. 7. Three views of the diopside structure. Arrows show crystallographic directions.

It should be noted that the blocks by themselves possess hexagonal symmetry, but that the method of stacking of the blocks degrades the symmetry to monoclinic. The shift between each block gives  $\beta = 95^\circ$ .

The cleavage takes place through the K planes. A system of "open" channels also runs through the structure in the (001) K planes. These openings probably are the loci of deposition of the exsolution growths of hematite and rutile frequently found in muscovite and phlogopite, respectively.

Ball sizes were so chosen as to maintain as nearly as possible the relative values of the radii proper to the various kinds of atoms in the crys-

tal. The OH groups, which are strongly polarized in the crystal, are represented by single balls in the model. The most satisfactory ball size for OH was found by calculation to be  $1\frac{5}{16}$ ". This size necessitates increasing the Al atoms slightly above their proper diameter, but maintains the interplanar spacing rather closely. The drilling coordinates calculated for the adjusted structure, are given in Table 4. The data comprise one unit cell plus enough exterior atoms to give the model a hexagonal aspect.

TABLE 4. DATA FOR THE CONSTRUCTION OF A PACKING MODEL OF MUSCOVITE

Ball designation	Ball diameter	Number of balls required for model as illustrated in Fig. 10	Drilling coordinates		Pin joins ball to
			$\rho$	$\phi$	
K	$1\frac{3}{4}$ "	14	59 121	0, 120, 240 0, 120, 240	basal O basal O
OH	$1\frac{5}{16}$ "	28	90	0, 120, 240	apical O
Al	$\frac{3}{4}$ "	51	(one through hole)		apical O
basal O	$1\frac{5}{16}$ "	48	90 145	0, 60, 180, 240 30, 210	basal O apical O
basal O	$1\frac{5}{16}$ "	126	90 145 59	0, 60, 180, 240 30, 210 120, 300	basal O apical O K
apical O	$1\frac{5}{16}$ "	48	35 90 122	0, 120, 240 60, 180, 300 30	basal O OH Al
apical O	$1\frac{5}{16}$ "	48	35 122	0, 120, 240 330	basal O Al

The model is best assembled by making each single mica sheet with its OH atoms separately (Figs. 8, 9), then pinning these sheets together with K atoms to form the blocks already mentioned, and finally stacking the completed blocks to form the entire cell (Fig. 10). The blocks are pinned together by means of the Al atoms. The Al balls should be drilled with a single through hole, the other bonds being eliminated, and be attached by a single  $1\frac{1}{2}$ " pin. The pins should all face in the same direction (Fig. 9), and the overlying block can then be slid directly on the lower block.

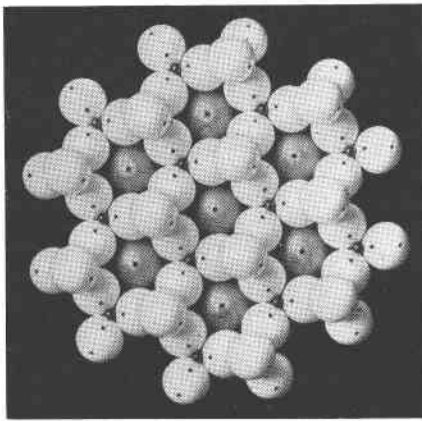

FIG. 8. Planar  $\text{Si}_4\text{O}_{10}$  sheet. Alternate apical oxygens are left off, exposing the Si atoms in the interior of the  $\text{SiO}_4$  tetrahedra. In constructing the sheet, the alternate missing apical oxygens are attached directly to the OH balls and this network is pinned to the mica sheet as a unit. Alternate oxygen bonds on the OH balls are eliminated for ease in construction.

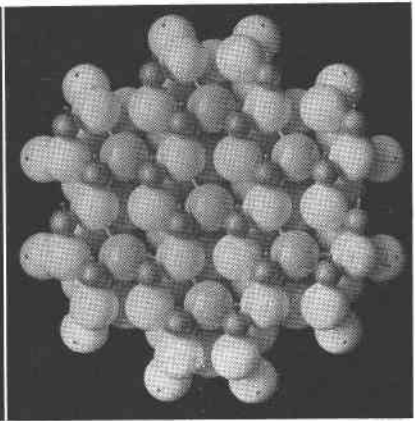

FIG. 9. Completed "mica sheet." The alternate apical oxygens and the OH groups, missing in Fig. 8, are shown in place together with the Al atoms.

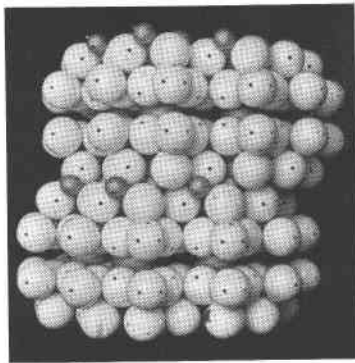

FIG. 10. Completed model. The model is viewed almost along  $b$ , and the monoclinic nature of the cell can be seen. The plane of cleavage through the K atoms, and the channels in this plane are apparent.

#### SANIDINE

(C. S. Lord and V. M. Lopez)

The structure of sanidine has been described by Taylor.<sup>10</sup> Certain

<sup>10</sup> Taylor, W. H., The structure of sanidine and other feldspars, *Zeits. Krist.*, vol. 85, p. 425, 1933.

permissible generalizations and simplifications have been adopted in this note in order to avoid needless complexity in the calculation and construction of the model.

The space group is given as  $C_{2h}^3$ . Alternative unit cells with symmetry elements (as given by Taylor) and the correlation of the model with his cells are shown in Fig. 11. Essential symmetry elements which cannot be illustrated in Fig. 11 are given in Taylor's paper. All further constructional data, with appropriate generalizations as justified below, are derived directly from these drawings.

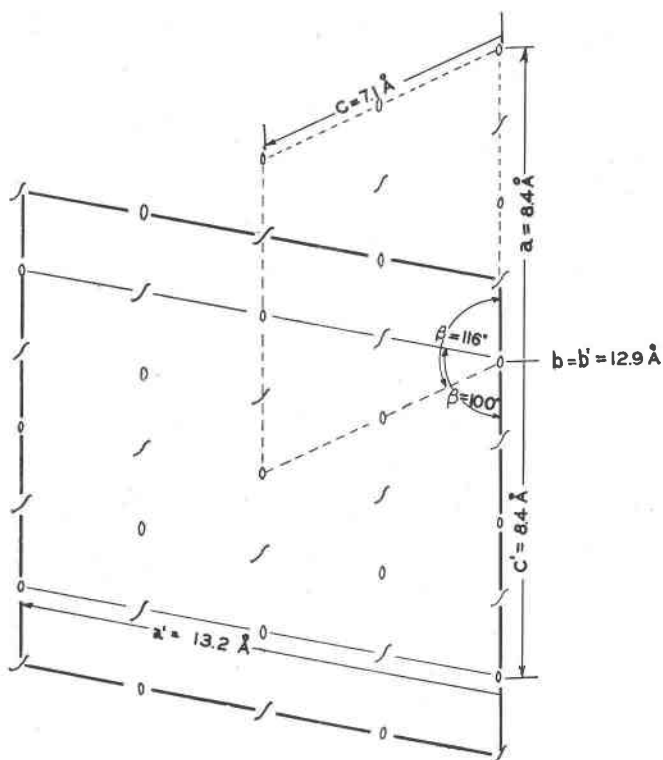

FIG. 11. Two alternative unit cells as given by Taylor. The heavy outline shows the arbitrary limit of the model.

It is difficult to visualize the structure from Taylor's drawings because all atoms are shown as points. Since the fundamental unit of the structure is a tetrahedron of oxygen atoms enclosing either a Si or Al atom, his point drawings can at once be simplified by substituting a solid

tetrahedron for each group of oxygen atoms, as in Fig. 12(a). Si and Al atoms were omitted from these drawings because they occupied a fixed position within these solid tetrahedra.

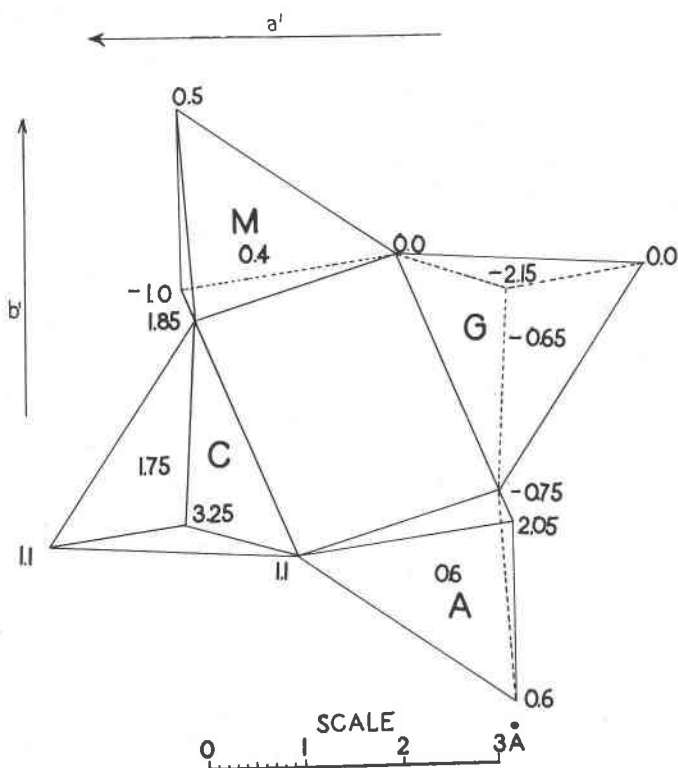

FIG. 12(a). The "basic ring" of tetrahedra as given by Taylor. Simplified only by the substitution of solid tetrahedra for his "point drawing." Viewed in plane of  $a'b'$  of Fig. 11.

Taylor has pointed out that the fundamental tetrahedra may be conveniently grouped into "basic rings" of four tetrahedra each and the completed structural model may be built up of a series of these basic rings suitably oriented and linked.

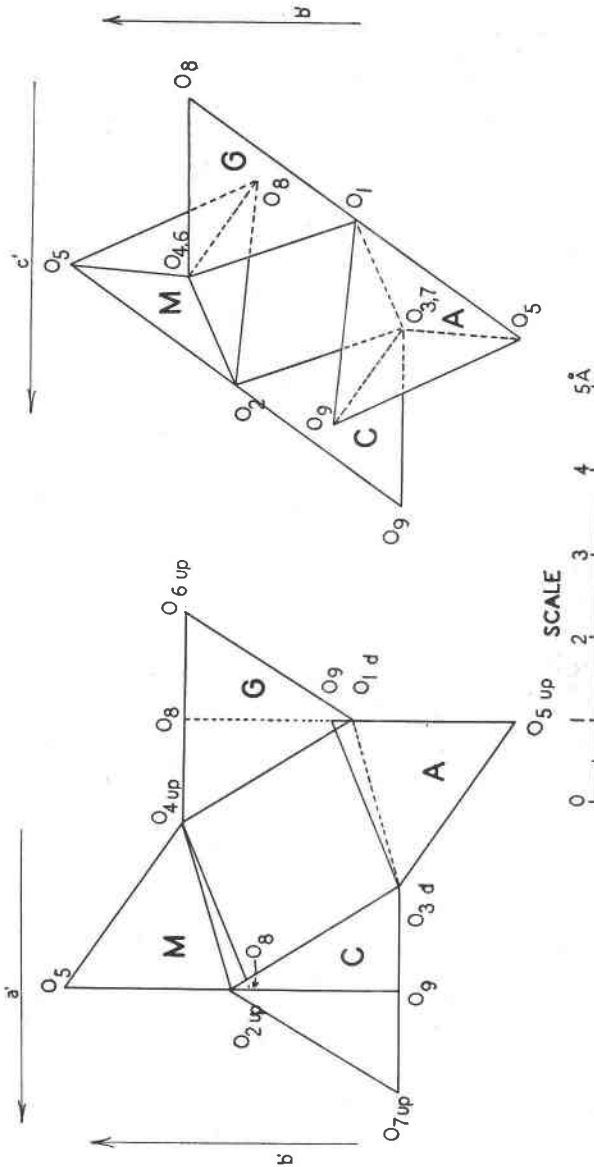

FIG. 12(b). Oriented and regularized "basic ring" of sanidine as used in the model. Same view as Fig. 12(a). This drawing is used to calculate the drilling coordinates of O<sub>1</sub>, O<sub>2</sub>, O<sub>3</sub>, O<sub>8</sub>, and O<sub>4</sub>.

The basic ring was first simplified and regularized. This brought it to the form shown by the group *MCAG*, Figs. 12(b) and 13. This ring was then expanded by symmetry operations to form a sheet of four such

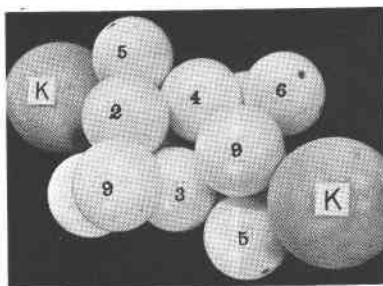

FIG. 13. Completed basic tetrahedron ring corresponding to the tetrahedron *MGHC* of Fig. 12(b), in plane of axes *a'b'*. K atoms are bonded to  $O_6$ .

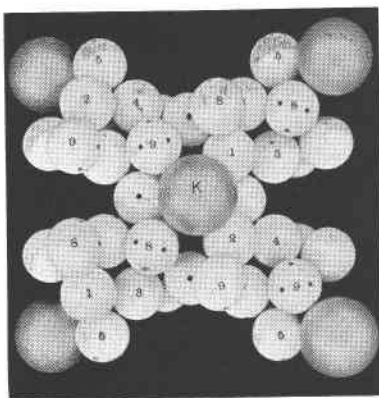

FIG. 14. "Sheet" comprising four basic tetrahedra rings with attendant K atoms. Numbers correspond to those used throughout the sanidine description. Viewed normal to the *a'b'* axes.

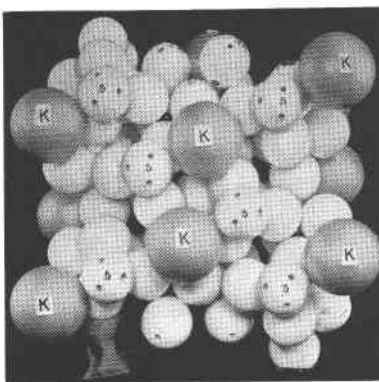

FIG. 15. Completed sanidine model oriented as Fig. 11. Viewed parallel to the *b'* (or *b*) axis.



rings. K atoms were added and the completed sheet is shown in Fig. 14. Such a sheet lies in the plane  $a' b'$  (Fig. 11). Three similar sheets, suitably bonded, complete the model of  $1\frac{1}{2}$  unit cells as shown in Fig. 15.

In calculating the drilling coordinates, the tetrahedral groups were first regularized. Taylor's calculations show that the structure is made up of tetrahedra in which the Si-O and the O-O distances vary between 1.55 to 1.75 Å and 2.55 to 2.95 Å, respectively. It was not practical to construct a model of such complexity and the following simplifications were adjusted to the available ball sizes:

- (1) regular tetrahedra were used
- (2) O-O distances were taken as 2.50 Å.

The substitution of these regular tetrahedra at once necessitated a slight modification of the structure as given by Taylor. The "basic ring" was modified from the given form, as shown by the same group in Fig. 12(b). From this figure the drilling coordinates were calculated for the oxygen atoms designated  $O_1, O_2, O_3, O_4$ .

In Fig. 16, the selected ring ( $MCAG$ ) is shown oriented with respect to the symmetry elements so as to preserve the required symmetry and to properly pack about the K atoms. From this figure the drilling coordinates of  $O_5, O_6, O_7, O_8$  and  $O_9$  were determined. Atoms  $O_5, O_8$  and  $O_7$  link the selected ring to three other rings and serve to complete one sheet of the model (Fig. 16). Atoms  $O_8$  and  $O_9$  link this sheet to other sheets above and below.

With Taylor's geometry of the silicate linking, our arbitrary oxygen radius would have required a K atom radius of  $2.85 - 1.25 = 1.60$  Å. However, our idealized model requires the K atom to be 1.72 Å, and this is the size we used. All the K atoms lie on reflection planes.

Drilling coordinates and other data are given in Table 5. The initial hole drilled for all oxygen atoms is not used as a bonding hole; this simplifies calculation of coordinates and aids in orienting the ball. In all cases these initial holes lie parallel to the " $C'$ " (or " $a$ ") axis and hence point either "up" or "down" in the cell as shown in Fig. 11. The designations "up" or "down" in the working drawings (Figs. 12 and 16) refer to the orientation of this initial hole on the  $C'$  axis and serve to orient the corresponding oxygen atom while constructing the model. K atoms were bonded by one pin only (to the  $O_5$  atoms), hence the complete environment of the K atoms is lacking toward the border of the model. All oxygen atoms are shared by two tetrahedra.

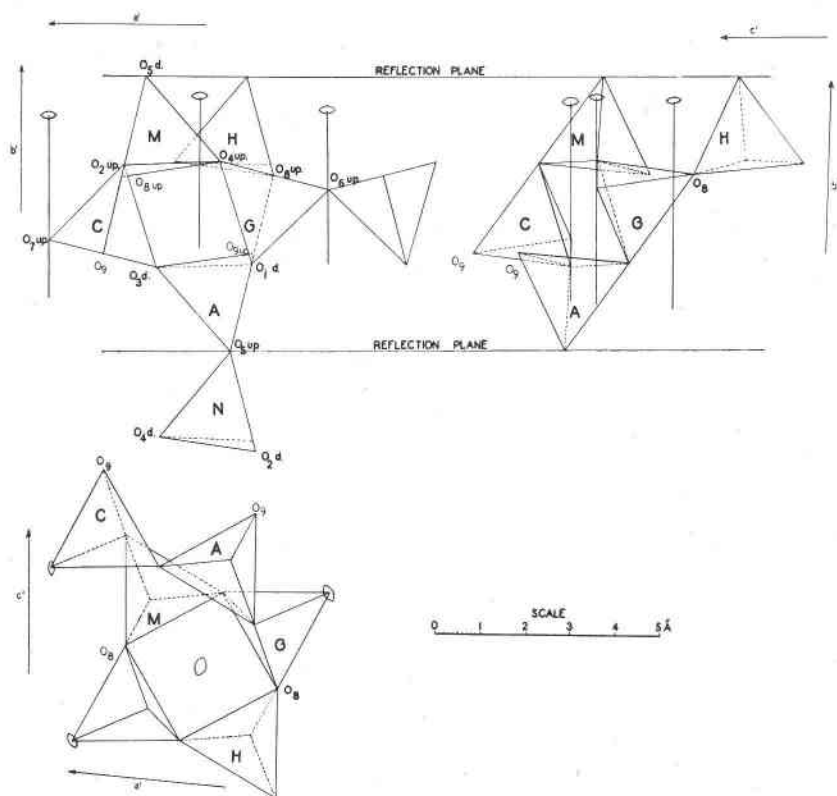

FIG. 16. Basic ring of tetrahedra expanded by symmetry operations and used to calculate the drilling coordinates of  $O_6$  and  $O_8$ .  $O_7$  and  $O_9$  are reflections of  $O_6$  and  $O_8$ , respectively. Initial holes marked "up" and "down" as in Fig. 13.

TABLE 5. DATA FOR THE CONSTRUCTION OF A PACKING MODEL OF SANIDINE

Ball designation*	Ball diameter	Number of balls required for $1\frac{1}{2}$ unit cells	Drilling coordinates		Pin joins ball to
			$\rho$	$\phi$	
O <sub>1</sub>	1 $\frac{1}{4}$ "	14	0	0	
			54.5	0	
			107	32, 328.5	
			121.5	254	
			125.5	180	
			174	0	
O <sub>2</sub>	1 $\frac{1}{4}$ "	14	0	0	
			54.5	0	
			107	31.5, 328.5	
			121.5	106	
			125.5	180	
			174	0	
O <sub>3</sub>	1 $\frac{1}{4}$ "	14	0	0	
			58.5	164	
			90	0	
			93.5	215	
			107.5	58.5	
			118.5	157.5	
O <sub>4</sub>	1 $\frac{1}{4}$ "	14	0	0	
			58.5	196	
			90	0	
			93.5	145	
			107.5	301.5	
			118.5	202.5	
O <sub>5</sub>	1 $\frac{1}{4}$ "	20	0	0	K
			58	0	
			62.5	75.5, 284.5	
			93.5	130.5, 229.5	
			125.5	75.5, 284.5	
O <sub>6</sub>	1 $\frac{1}{4}$ "	4	0	0	
			30	14	
			73.5	315.5	
			90	14, 165.5	
			106.5	224	
			150	165.5	

\* Subscripts in this column correspond to numbers on oxygen atoms in photos and to subscripts on same atoms in Figs. 12 and 16.

TABLE 5 (Continued)

Ball designation*	Ball diameter	Number of balls required for $1\frac{1}{2}$ unit cells	Drilling coordinates		Pin joins ball to
			$\rho$	$\phi$	
O <sub>7</sub>	1 $\frac{1}{4}$ "	4	0	0	
			30	346	
			73.5	44.5	
			90	194.5, 346	
			106.5	136	
			150	194.5	
O <sub>8</sub>	1 $\frac{1}{4}$ "	18	0	0	
			30	0, 180	
			35	270	
			114.5	119.5	
			117.5	186.5	
			173.5	119.5	
O <sub>9</sub>	1 $\frac{1}{4}$ "	18	0	0	
			30	0, 180	
			55	90	
			114.5	240.5	
			117.5	173.5	
			173.5	240.5	
K	1 $\frac{1}{4}$ "	18	0	0	O <sub>6</sub>
			122	0	